

SANI-PALLET®

A Sanitary Material Handling Solution

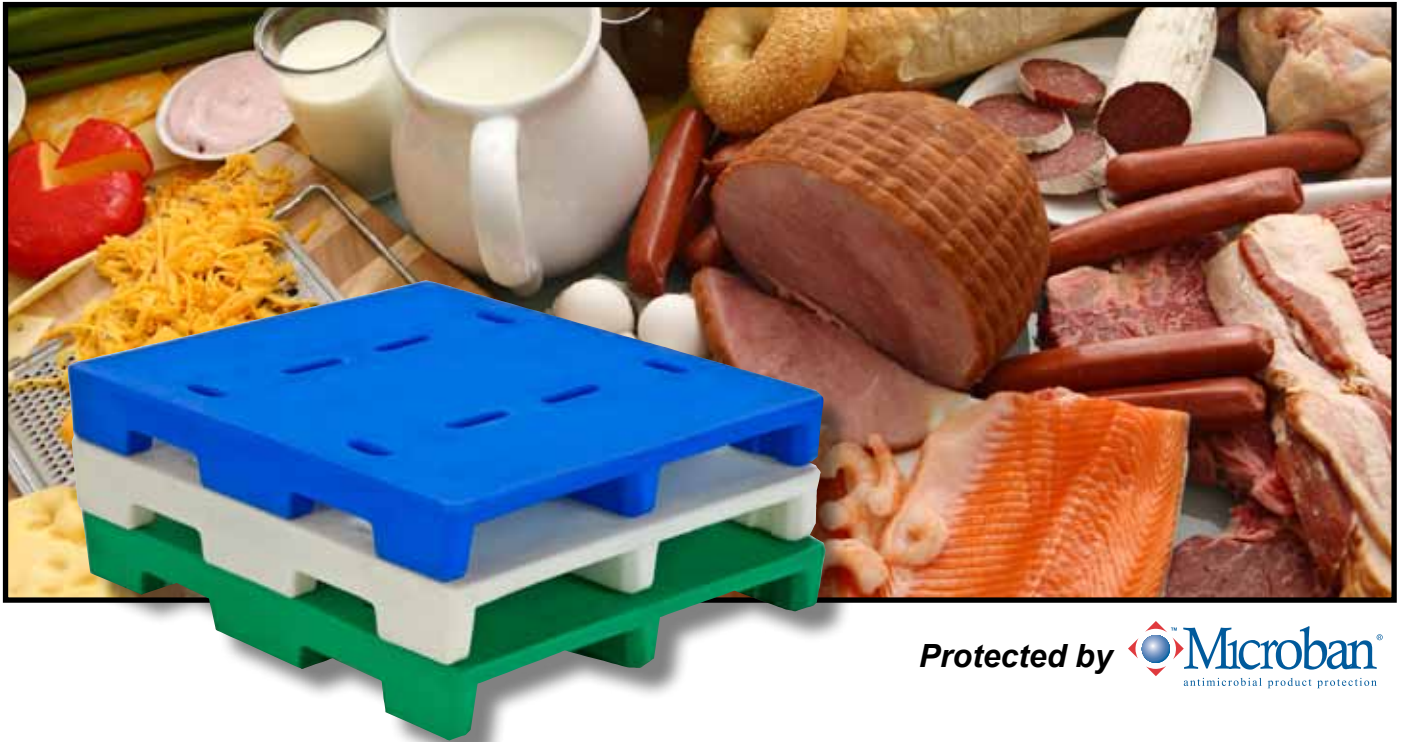

Protected by  **Microban®**
antimicrobial product protection

Maximize sanitary food handling practices at your plant with the industry's most hygienic plastic pallet design. SANI-PALLET® eliminates the sidewall seams, gaps, holes and other bacteria traps associated with other plastic pallets. And now Sani-Pallet® features built-in Microban® antimicrobial protection for an added layer of protection against odor and stain causing bacteria. Microban® protection is not a substitute for normal cleaning practices, but is designed to keep the Sani-Pallet® cleaner for longer. A seamless HDPE construction has been meticulously configured so liquid residue is unable to pool or collect on any exterior container surface, making pallet inspection and cleaning more efficient than ever.

Best of all, SANI-PALLET® comes equipped with an impact resistant double wall HDPE construction that delivers the industry's highest useful-life-to-cost ratio, so you can be assured optimum sanitary service for years to come. Contact your Bonar representative today and learn more about SANI-PALLET®, and many other exciting Microban® protected material handling products.



1005 Atlantic Drive • West Chicago, IL • Customer Service: 800-295-3725 • Ext. 14 • Fax: 630-293-0930
Other Manufacturing Locations: Lincoln, Nebraska, Marked Tree, Arkansas, Philippi, West Virginia, Mancelona, Michigan

www.bonarplastics.com

SANI-PALLET®

One-Piece Seamless Design

Eliminates the gaps and seams prevalent in other plastic box designs that can contribute to trapping bacteria.

Impact resistant HDPE is optimized within a unique rotational molding process, resulting in superior durability characteristics.

Thick double wall construction ensures longer lasting, more durable performance than other plastic pallets.

.500+ radius corners throughout design eliminates the common honeycomb structures within injection molded pallets, which makes cleaning and inspection much easier.



Eliminate the gaps, seams and other bacteria traps associated with other plastic pallet designs.

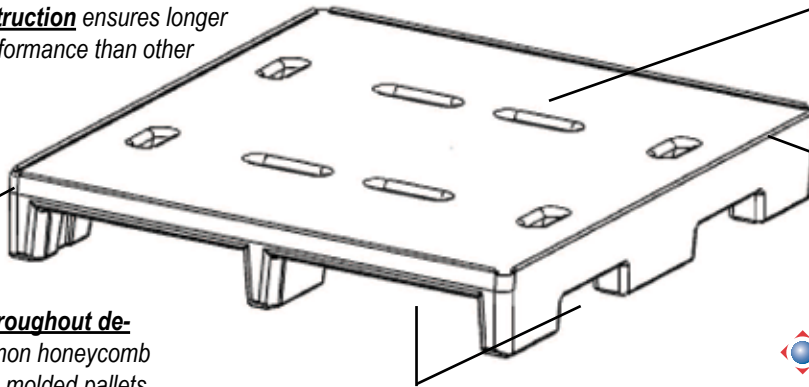

Molded-in drain slots allow liquid to drain off pallet more quickly, and can also be used as hand holds for more ergonomic handling of the pallet.

Optional raised outer edge for applications requiring more resistance to payload shippers.

4-way forklift and pallet jack access provides versatile material handling options within the plant and over-the-road.



Microban® technology is infused to inhibit the growth of bacteria that can cause stains, odors, and product degradation keeping Bonar Plastics products cleaner for longer.

Microban® protection is not designed to protect users against food borne illness and is not a substitute for normal cleaning practices.

Specifications

Dimensions: 40" x 48" x 6.25"(Height)
Approximate Tare Weight: 45 lbs. (2000), 55 lbs. (3000)
Weight Capacity: 2000 lbs., 3000 lbs.

MICROBAN® is a registered trademark of Microban Products Company.



1005 Atlantic Drive • West Chicago, IL • Customer Service: 800-295-3725 • Ext. 14 • Fax: 630-293-0930
Other Manufacturing Locations: Lincoln, Nebraska, Marked Tree, Arkansas, Philippi, West Virginia, Mancelona, Michigan

www.bonarplastics.com